

# Enhancing Power Delivery System Designs with CMOS-Based Isolated Gate Drivers



By Don Alfano, Silicon Labs

*Fully-integrated isolated gate drivers can significantly increase the efficiency, performance and reliability of switch-mode power supplies compared to legacy solutions.*

## Introduction

As emerging green standards challenge designers to deliver more energy-efficient, cost-effective and reliable power delivery systems in smaller form factors, the need for greater power and isolation device integration becomes increasingly important. A critical building block within ac-dc and isolated dc-dc power supplies is the isolated gate driver. While optocoupler-based solutions and gate-drive transformers have been the mainstay for switch-mode power supply (SMPS) systems for many years, fully-integrated isolated gate driver products based on RF technology and implemented in mainstream CMOS provide a more reliable and power-efficient solution.

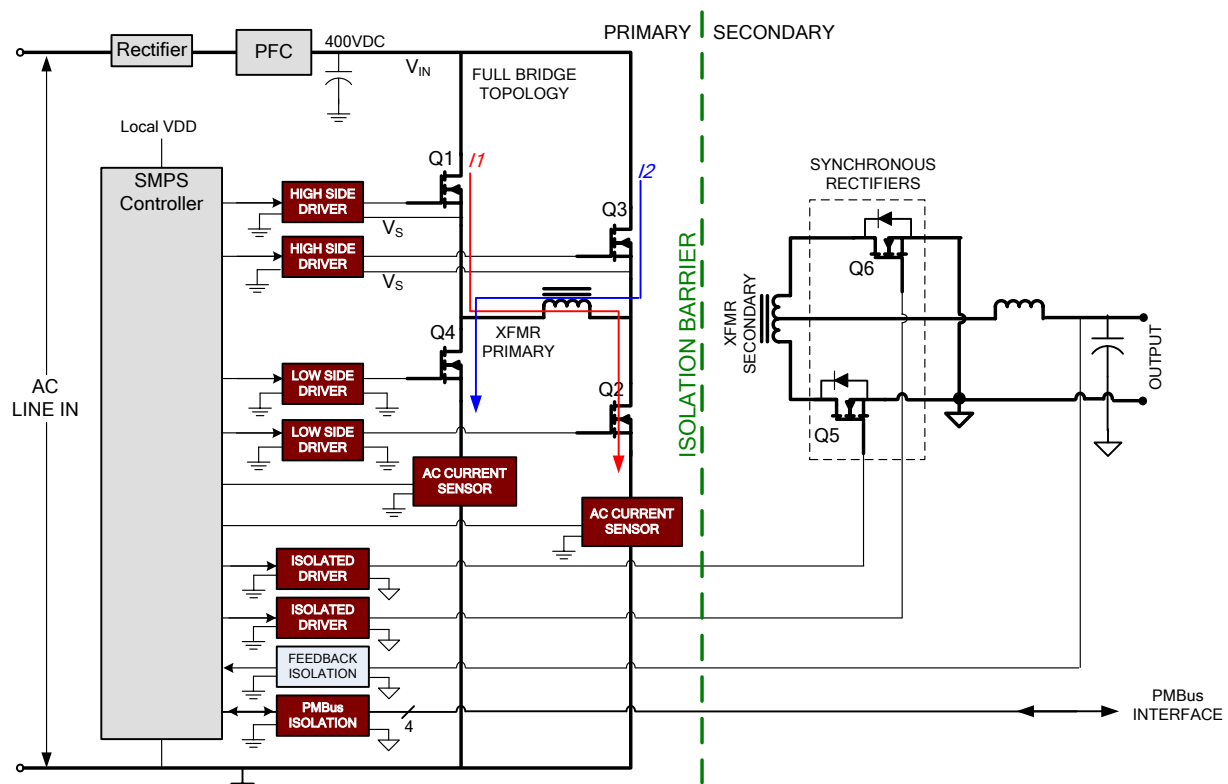

Figure 1: AC/DC Converter Based on Full Bridge Topology

## Anatomy of an Isolated Power Converter

Isolated power converters require power stage and signal isolation to comply with safety standards. Figure 1 shows an example of a typical ac-dc converter for 500 W to 5 kW power systems, such as those used in central office telecom rectifier supplies. From a high-level perspective, this two-stage system has a power factor correction circuit (PFC) that forces power system ac line current draw to be sinusoidal and in-phase with the ac line voltage; thus, it appears to the line as a purely resistive load for greater input power efficiency.

The high-side switch driver inputs in Figure 1 are referenced to the primary-side ground, and its outputs are referenced to the high-side MOSFET source pins. The high-side drivers must be able to withstand the  $400 V_{DC}$  common-mode voltage present at the source pin during high-side drive, a need traditionally served by high voltage drivers (HVIC). The corresponding low-side drivers operate from a low voltage supply (e.g. 18 V) and are referenced to the primary-side ground. The two ac current sensors in the low-side legs of the bridge monitor the current in each leg to facilitate flux balancing when voltage mode control is used.

The isolation barrier shown in Figure 1 is provided to ensure that there is no current flow between the primary- and secondary-side grounds; consequently, the drivers for synchronous MOSFETs Q5 and Q6 *must* be isolated. The secondary-side feedback path must also be isolated for the same reason.

## Gate Drive Solution Options

Although optocouplers are commonly used for feedback isolation, they are not fast enough for use in the synchronous MOSFET gate-drive isolation circuit. While faster optocouplers are available, they tend to be expensive and exhibit the same performance and reliability issues typical of optocouplers, including unstable operating characteristics over temperature and device age and marginal CMTI resulting from a single-ended architecture with high internal coupling capacitance. In addition, Gallium-Arsenide-based process technologies common in optocouplers create an intrinsic wear-out mechanism (“Light Output” or LOP) that causes the LED to lose brightness over time.

Given the above considerations, gate drive transformers have become a more popular method of providing isolated gate drive. Gate drive transformers are miniature toroidal transformers that are preferred over optocouplers because of their shorter delay times. While faster than optocouplers, gate drive transformers cannot propagate a dc level or low-frequency ac signal; they can pass only a finite voltage-time product across the isolation boundary, thereby restricting ON time ( $t_{ON}$ ) and duty cycle ranges. These transformers must also be reset after each ON cycle to prevent core saturation, necessitating external circuitry. Finally, transformer-based designs are inefficient, have high EMI and occupy excessive board space.

## An Optimum Isolated Gate Drive Solution

Fortunately, better alternatives to gate drive transformers and optocouplers are now available. Advancements in CMOS-based RF isolation technology have enabled isolated gate drive solutions that offer exceptional performance, power efficiency, integration and reliability. These highly-integrated CMOS devices are well positioned to supersede both optocouplers and gate drive transformers in SMPS applications.

Isolated gate drivers, such as Silicon Labs' *ISOdriver* family, combine RF-based isolation technology with gate driver circuits, providing integrated, low-latency isolated driver solutions for MOSFET and IGBT applications.

ISOdriver products are available in three basic configurations (see Figure 2): high-side and low-side isolated drivers with either separate control inputs for each output or a single PWM input, and a dual isolated driver. Each ISOdriver device is available in 0.5 A and 4.0 A peak output current and is available in 1 kV, 2.5 kV and 5 kV isolation ratings. The high-side/low-side versions have built-in overlap protection and an adjustable dead time generator (dual ISOdriver versions contain no overlap protection or dead time generator). As such, the dual ISOdriver can be used as a dual low-side, dual high-side or high-side/low-side isolated driver. These devices have a three-die architecture (see Figure 3) that causes each drive channel to be isolated from the others as well as from the input side. This allows the polarity of the high-side and low-side channel to reverse without latch-up or other damage.

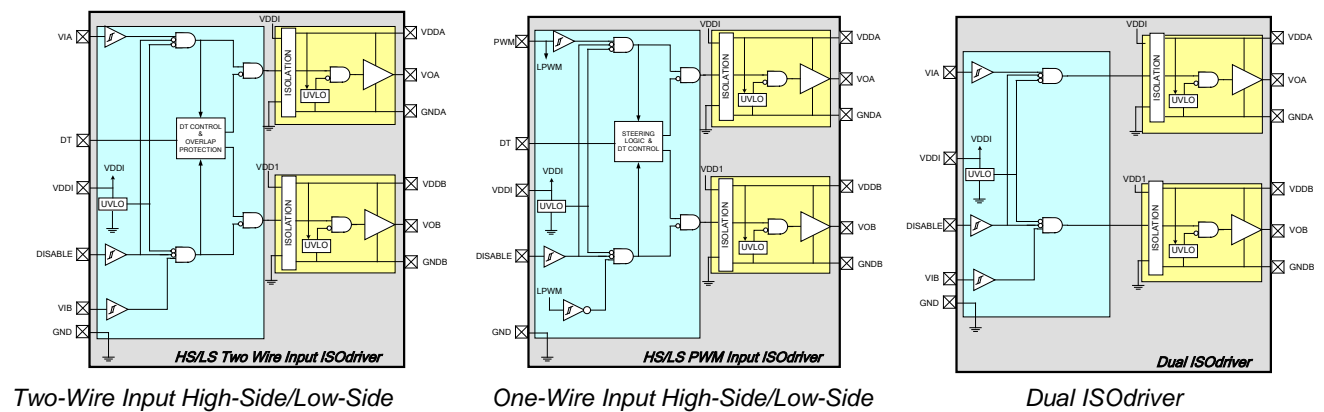

Figure 2: ISOdriver Family

For example, the high-side driver (*GNDA*) might ride on a common-mode voltage of 100 V while an adjacent driver (*GNDB*) might ride on a common-mode voltage of 200 V. These two common-mode voltages can reverse (i.e.  $GNDA = 200\text{ V}$ ,  $GNDB = 100\text{ V}$ ) without damaging or upsetting the driver. This feature makes the ISOdriver useful in systems with fast-changing common-mode voltages or when the input is a bipolar supply.

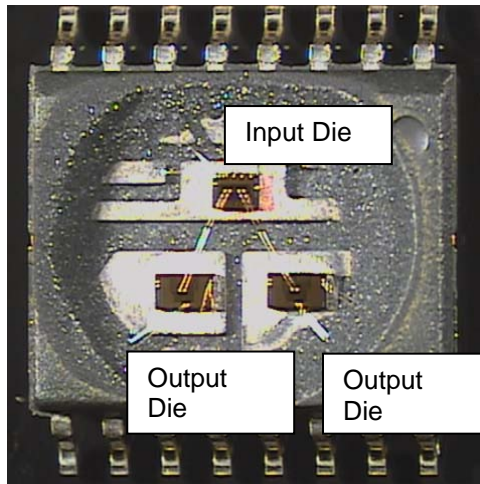

Figure 3: Decapsulated Three-Die ISOdriver

## Maximizing System Efficiency

The switching mode in high-side/low-side drive applications must be “break-before-make” to avoid efficiency loss from both MOSFETs being on at the same time (i.e. “shoot-through current”). This time period between switch transitions where both switches are off is referred to as “dead time” (Figure 4).

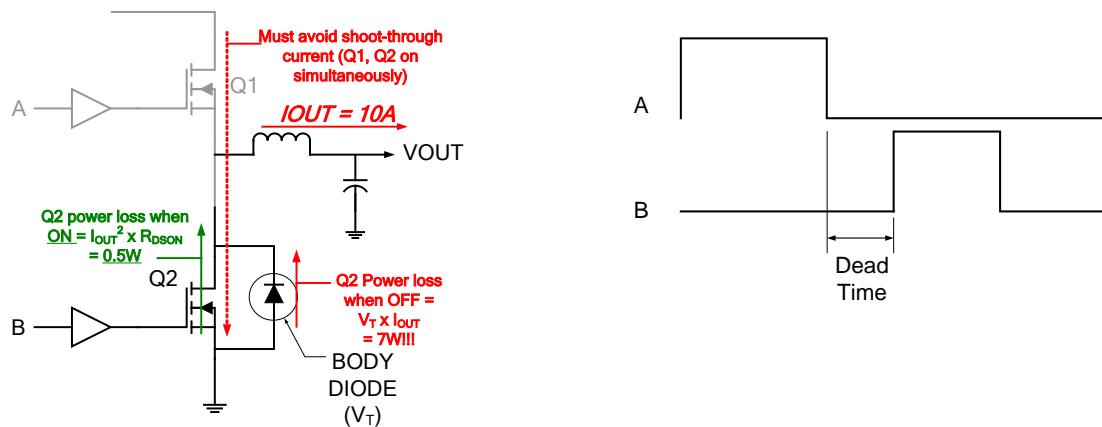
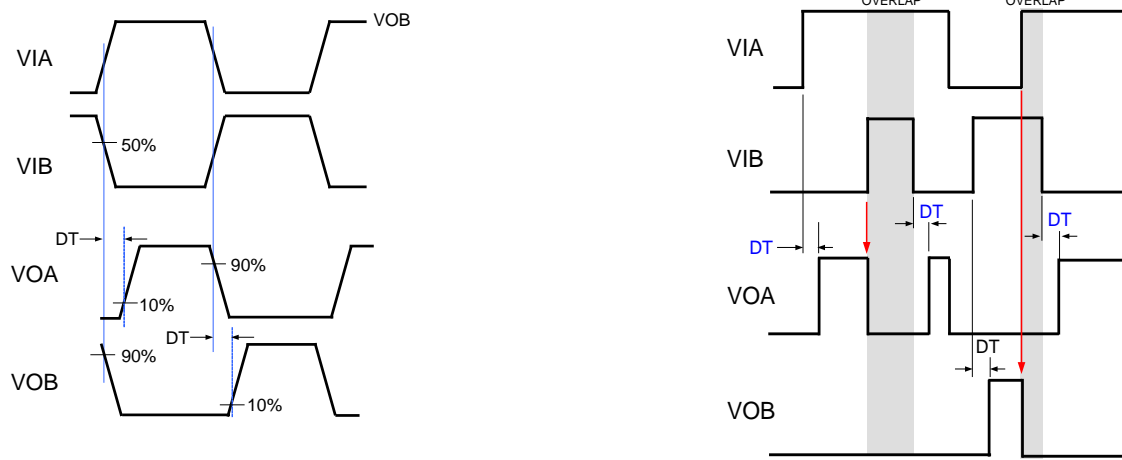

Figure 4: Dead Time

While an optimum amount of dead time can increase system efficiency, excessive amounts of dead time can reduce efficiency. As shown in Figure 4, the power dissipation of Q2 is only 0.5 W when Q2 is on but increases to 7 W when the body diode conducts while Q2 is off. Therefore, the amount of dead time added to the circuit timing must be only large enough to prevent shoot-through current. High-side/low-side ISOdrivers have an integrated dead time generator that can be adjusted from 4 ns to 950  $\mu$ s using an external resistor, allowing the user to optimize dead time.



Normal Dead Time Behavior

Dead Time Behavior during Overlap

Figure 5: ISODriver Dead Time Behavior

ISODrivers also contain overlap protection that causes outputs VOA and VOB to unconditionally go low in the event VIA and VIB simultaneously go high, as shown in Figure 5.

## Dual ISODriver

While dead time optimization can increase efficiency by as much as +4%, additional efficiency gains can be achieved by arranging MOSFETs in parallel or by increasing gate drivers to a single, larger MOSFET. In either case, a dual ISODriver can be useful in providing additional drive capability. Unlike dedicated high-side/low-side ISODrivers, the Si8232/5/6 dual ISODrivers have no built-in overlap protection or dead time setting.

The state of each driver output unconditionally follows that of its input as long as the device is powered. The two driver output circuits are isolated from each other and from the input, allowing the common-mode voltage of one driver to reverse polarity with respect to the other without damage (i.e. latch-up) or output errors. Figure 6 shows a common-mode voltage inversion where the polarity of the two drivers reverses without damage or upset, which can be helpful in systems with bipolar input supplies.

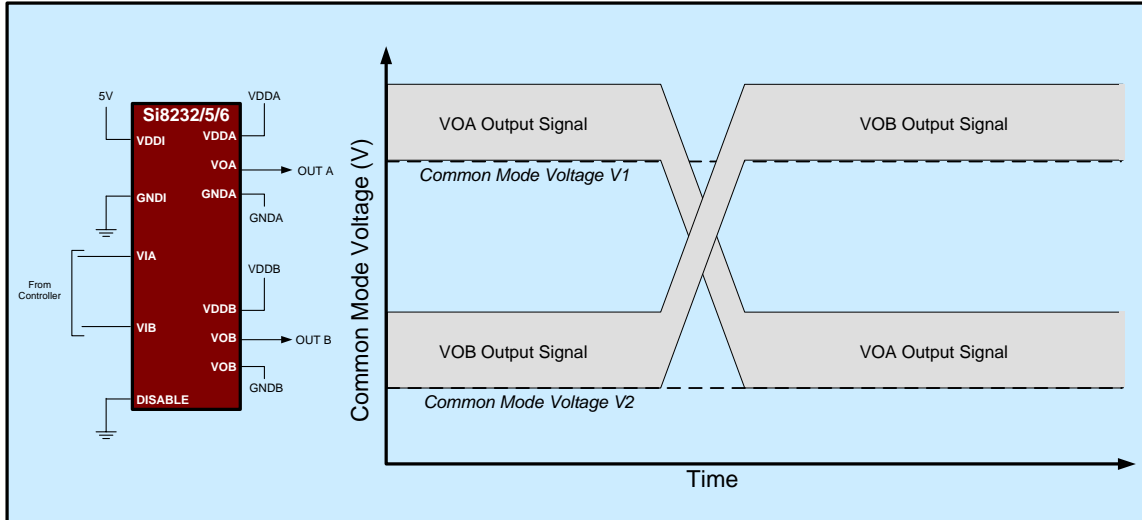

Figure 6: Common Mode Voltage Inversion

In many power applications, such as UPS systems and inverters, switches must be designed in parallel to enable the system to deliver rated power at high operating efficiencies. The combined capacitive loading of these switches requires either a higher peak current driver or a less desirable method of distributing the switches over multiple gate driver ICs. The circuit in Figure 7 shows each Si8232/5/6 output driving several common ground switches in parallel. When connected in this way, the dual ISOdriver can provide an equivalent peak drive current of 8 A while 50 ns propagation delay time ensures that all switches are driven off and on simultaneously.

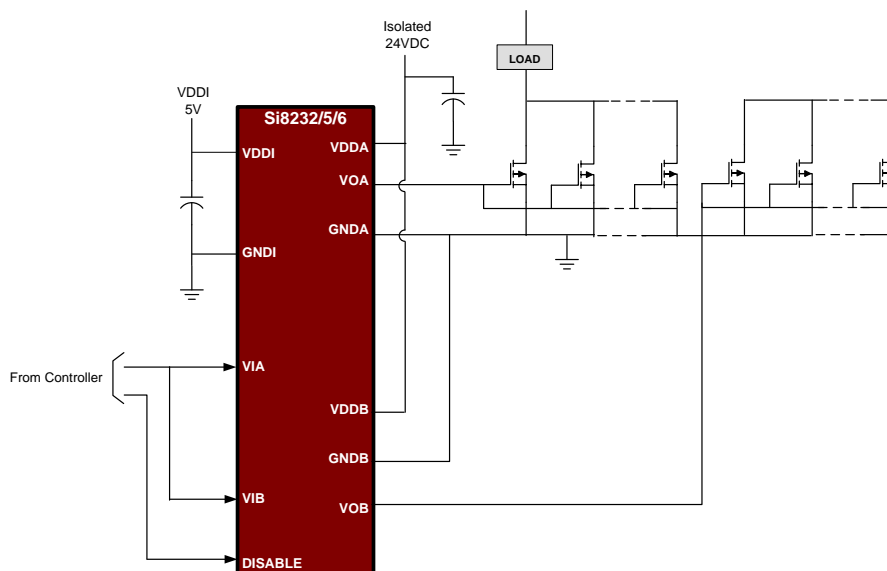

Figure 7: Paralleled Outputs for Increased Peak Output Current

Power circuits in high-voltage systems, such as imaging systems and plasma flat panels, have split ground systems to isolate higher voltages from lower voltages. In many cases, local supply regulators are built using a dedicated controller for each regulator. In other cases, the regulators may use a transformer-coupled multi-output design (using flyback or other transformer-coupled topology).

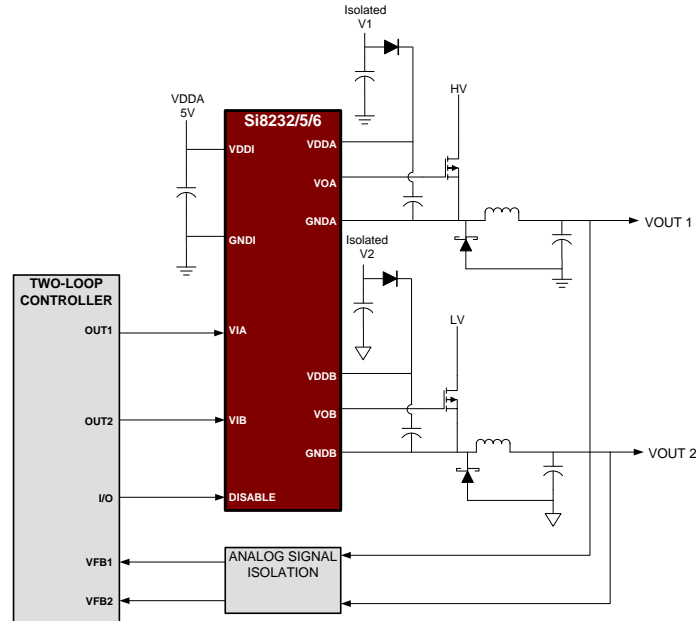

Figure 8: Dual Isolated Buck Converter

Figure 8 shows a dual output isolated buck converter using the Si8232/5/6 dual ISOdriver. A single two-loop controller is used with the ISOdriver to generate two stepped-down output voltages. The ISOdriver operates as an isolated dual high-side driver with each output isolated from both the adjacent output and the primary side. While this circuit uses a low-cost Shottkey freewheeling diode, a second dual ISOdriver can be added to control output synchronous rectifiers for higher efficiency.

## Conclusion

CMOS-based isolated gate drive technology, exemplified by Silicon Labs' ISOdriver family, offers substantial performance, reliability, integration and per-channel cost advantages over legacy isolation technologies, such as optocouplers and gate drive transformers. The Si823x and Si822x ISOdrivers are single-chip, isolated gate drivers that feature ultra-fast 50 ns propagation delays for increased timing margins. They also offer programmable dead-time control for higher system efficiency, stable operation over temperature and time, lower BOM costs and smaller PCB footprints.

The ISOdriver family is engineered to deliver industry-leading performance, high integration and exceptional value, providing an optimal isolated gate drive solution for a wide range of power delivery systems. With up to 5 kV of isolation, the ISOdriver products are well suited to safety-critical applications requiring high maximum continuous working voltages. Supporting output power supplies up to 24 V and 0.5 or 4.0 A peak output current, ISOdrivers efficiently drive MOSFET and IGBT power stages in high-performance, isolated switch mode power supplies.